

## Chapter 4

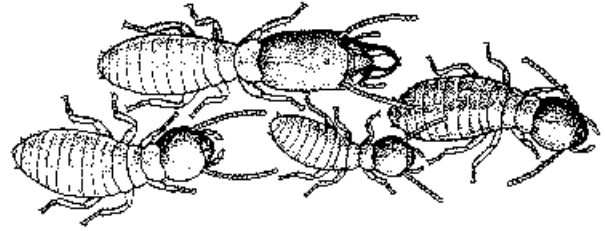

# Preventing Termite Infestations

Since termites are most active in the soil, the basement is often the place termites infest. When we build homes with basements, we keep them warm in the wintertime. This means that termites entering a basement below the frost-line can remain active and continue feeding even when the weather is very cold outside. The only basement that is impervious to termites is one that is completely sealed and that has no cracks in it, a rarity because there is nearly always a crack somewhere in the foundation or basement slab. Foundations help prevent termite infestations, but most foundation types have special problems associated with them.

## Basement Foundations

**Poured Concrete Foundation.** This is the most difficult foundation for termites to find a way through, but only if walls have no cracks in them. Remember that termites can enter through a crack of only 1/32 inch. To make concrete more termite proof, builders should reinforce the poured concrete with steel rods to prevent opening of the joints or cracks due to shrinkage.

**Block and Brick Foundations.** These basement foundations are at risk because cracks often develop as the foundation ages. With hollow blocks, termites can enter through a crack and follow the hollow spaces vertically and enter a house virtually undetected. Where hollow block masonry is used on new construction, it should have a solid capping of four-inches of reinforced concrete.

**Crawl Space.** Crawl spaces are often insufficiently ventilated, which makes them ideal environments for termites to tube vertically. In many crawl spaces, the space between the soil level and horizontal timbers is inadequate to prevent termite tubing. Experts recommend an 18-inch vertical distance between the soil and structural wood.

**Slab.** Slab construction results in structural wood timbers fairly close to the soil level and makes this type of construction at high risk of termite infestations. Common construction techniques serve to create termite entry into the structural part of the home. When framing walls, builders often nail lumber to the slab with a nail gun. Nailing into the slab may weaken the slab and creates cracks that allows termites to have easy access to construction lumber.

**Finished Basements.** Finished basements are a problem because inspection is so difficult. Termite inspectors will not give complete assurance that a structure is free from termites because termites might be active behind finished walls and impossible to see. To make a finished basement more termite proof, consider the following:

- Finished basement walls should be supported on a concrete base rather than nailing lumber into the basement slab, which often results in cracking. Nailing lumber into foundation walls may also cause cracks.
- Repair cracks in basement walls, floors before covering.
- Use pressure-treated lumber in all below-ground construction (see the *Termite Resistant Materials* section, later in this chapter).

## Eliminate Conducive Conditions

Like other animals, termites need food and water to survive and thrive. Subterranean termites are most plentiful in natural woodlands where there is an abundant supply of both. They rarely need to feed on wood much above the ground because so much wood on or in the ground is readily available. For a termite colony, this is paradise. In northern climates, cold winter temperatures limit termite activity because, like other cold-blooded organisms, termites aren't active when the temperature is below 50° F or so. They cannot cross a frost barrier during the wintertime, so much of the termite activity in Nebraska is seasonal, taking place between April and October.

When we build houses, we clean up most of termites' natural sources of food so the wood that we leave for them is the wood in our homes. Unlike the abundance of wood lying on the ground in woodland settings, the wood in structures is usually not that easy for termites to find. Termites must find cracks in basement foundations or concrete slabs to allow them access to construction timbers. When traveling in dry air, termites construct and travel in mud tubes and avoid desiccation by keeping the tubes moist. Understanding the importance of food and moisture in termite survival will help you understand conditions conducive to termite infestations and take actions which may prevent infestations.

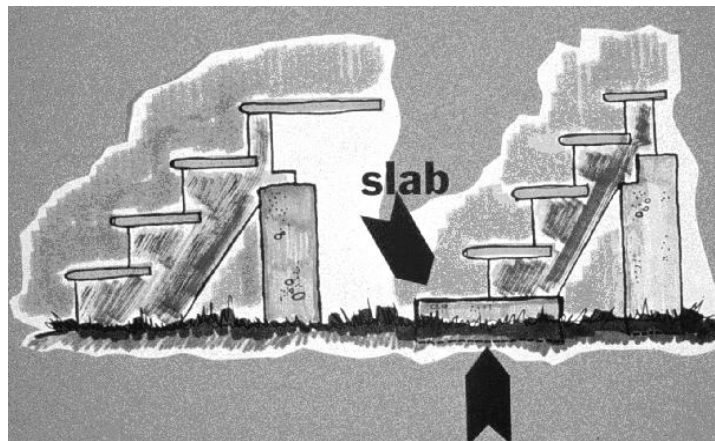

**Figure 4-1. Avoid direct wood to soil contact.**

**Eliminate Wood to Ground Contact.** Studies have shown that about 90 percent of structural termite infestations can be traced to wood that is in contact with the soil. Wood-soil contact provides termites easy access to food and water from the soil, and frequently, a hidden way into the structure. Wood siding, latticework, door and window frames and other wood should be at least six inches above the grade level. Eliminating wood-soil contact can require regrading or pulling soil or mulch away from the foundation.

When inspecting your property, look for areas that wood and soil are in direct contact. Consider the following:

- Wood posts and other structural elements should never penetrate concrete floors (basements and slab construction homes, garages). Replace with metal posts but be sure to remove all wood imbedded in the concrete.
- Be sure to check basement windows and frames. They should be made of metal or pressure-treated wood. (See section on *Pressure-Treated Lumber*, later in this chapter)
- Outdoor wood porches and steps should be supported by a concrete base, at least six inches above grade.
- Where wood to soil contact cannot be eliminated, treated wood should be used. For more information, see the *Pressure-Treated Lumber* section, later in this chapter.

**Remove Wood Debris.** All wood or cellulose material that is left on or below the soil surface provides a convenient source of food for termites. Construction debris in the form of wood scraps as well as stumps, roots, cardboard boxes, and newspapers should be removed from under and around the building. Be sure to check under crawl spaces and porches. In new construction, wood scraps should never be buried in the fill (**Figure 4-2**). Stack firewood above the ground on a cement slab and store the firewood away from the house.

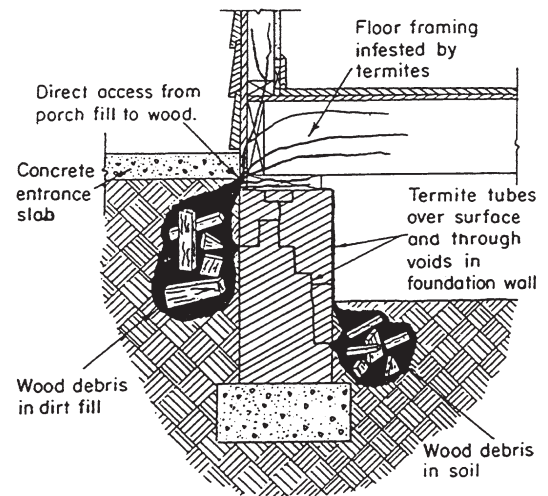

**Figure 4-2. Termite colonies can develop in wood debris.**

**Remove Vegetation and Mulch.** Shrubs, vines, trellises and other dense vegetation should be removed from the side and foundation of the house. Vegetation traps moisture, which is attractive for termites. Dense vegetation makes it more difficult to inspect the house and detect their presence. Plants near the house also may need watering, which brings moisture close to the foundation and may increase termite activity.

**What About Mulch?** Mulching with shredded wood or bark chips around bedding plants, trees and shrubs is used because mulch is attractive, holds moisture, insulates soil from extreme temperatures, and prevents weed growth. However, any cellulose-containing substance touching the soil might serve as a food source for termites. In addition, the moisture-holding properties of wood/bark chips and insulation may increase the attractiveness to termites in mulched areas. How should you manage mulch next to your home to prevent a potential termite problem?

Studies at the University of Maryland compared different types of mulch, including pea gravel. Researchers found that termite activity was greater under all types of mulch compared with bare soil, probably because soil moisture was greater in the mulched areas. Based on these studies, they concluded that it is best to have bare soil next to foundations. This reinforces the need to slope soil away from the house and use gutters and downspouts to move rainwater away from the house and keep the foundation area dry.

Studies have also determined how insect population densities were related to the depth of mulch. More insects and other small arthropods, including termites, were found where deeper amounts of mulch were used. To minimize termite foraging in specific areas, particularly near foundations, it is best to use no more than 3-inches of mulch.

The type of wood mulch may also influence termite feeding. Termites prefer softwood mulches, like pine and fir compared with hardwood mulches. Termites also prefer fungus-decayed wood to sound wood, which increases the attractiveness of “recycled” wood that has already begun to decay. Cedar, cypress and redwood mulches may be somewhat resistant to termites initially because these woods have resins that may make them less palatable. However, over time, these resins leach into the soil. According to Michael Potter, termite researcher at the University of Kentucky, “no wood or plant-based material is immune to termite attack”.

Because insecticides quickly break down under ultraviolet light, spraying insecticides on mulch to prevent termite activity is of little value and not recommended.

**Eliminate Moisture Problems.** Termites are more likely to infest a structure if the soil around it is constantly moist. Make sure that water drains away from the building. Check to make sure gutters and down spouts are in good repair and divert water away from the building.

Roof or plumbing leaks can enable termites to survive and colonize structures above the ground without soil contact. A termite inspector may be able to detect such moisture problems in the wall with a moisture meter.

Humid conditions in a crawlspace can promote termite problems because termites are able to construct longer mud tubes. Humidity in crawlspaces can be reduced by providing adequate ventilation and creating a vapor barrier. Most building codes call for 1 square foot of vent opening per 150 square feet of crawlspace area. Vapor barriers can be created by covering the soil with 4-6 mil polyethylene sheets.

**Remedy Difficult or Unusual Construction Problems.** Termite infestations can get started because of the way a building is constructed. Sometimes unusual construction will make it difficult or impossible to treat with a chemical barrier. Remodeling portions of an existing home may prevent future termite problems.

**Increase Crawlspace Clearance.** A condition that promotes termite infestations is inadequate clearance between the soil surface and the structural wood above a crawlspace. Too little clearance makes it difficult to inspect properly. In addition, it is easier for termites to tube over the foundation to get to the wood. A minimum of 18 inches should exist between horizontal timbers and the soil. You may need to excavate soil to achieve this distance.

**Replace Dirt-filled Porches and Steps.** A significant percentage of failed chemical barrier treatments are related to dirt-filled concrete porches or steps. This construction problem brings the soil in the porch or steps above the exterior wall of the building and near the structural wood of the

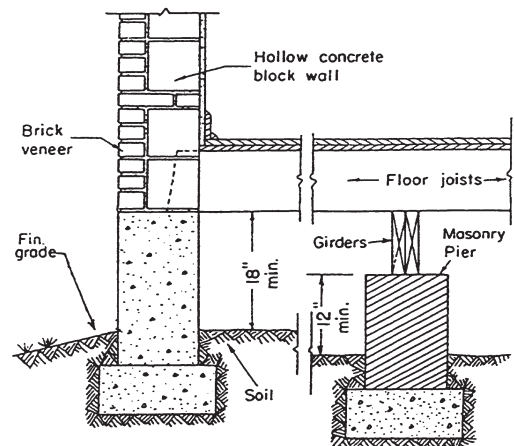

**Figure 4-3. Provide adequate clearance between wood and soil.**

house. When termites have entered the home from this construction problem, it can be particularly difficult to treat it properly. One possible solution is to remove and replace the porch or steps.

**Eliminate Stucco or Brick Below Grade Level.** Stucco or brick veneer that extends below the soil level is another way termites can get into a structure because a crack may form between the brick veneer or stucco and the structure. It may be necessary to excavate soil away from the foundations or remove lower rows of brick.

**Remove or Replace Rigid Board Foam Insulation.** Since the early 1980's, the use of rigid foam insulation has increased in new home construction to increase energy efficiency. By 1992, 50 percent of all new construction contained some type of foam insulation. Panels of this type of insulation are typically installed on interior or exterior foundation walls, but all construction types (slabs, crawlspaces and basements) are likely to contain rigid board insulation. Termite problems arise when exterior insulation panels extend below the soil line because termites may tunnel undetected through or behind it into the structure. Termites living behind these foam panels can avoid the chemical barrier, and chemical treatments cannot penetrate the foam because it resists wetting. Methods of controlling termites behind below ground insulation are difficult at best, and some companies may refuse to use a barrier treatment on structures with foam insulation or provide no guarantee of treatment. One remedy is to excavate and remove the insulation panels. Another option might be to use or replace insulation panels with panels impregnated with boric acid.

## Termite Resistant Materials

### Pressure-Treated Lumber

One way to prevent termite damage is to use pressure-treated wood whenever wood comes within six to twelve inches of the soil. It is also a good idea to use pressure-treated wood when finishing basements. There are excellent reasons for using pressure-treated lumber. Pressure-treated wood is resistant to termites and decay so its use extends the life of our forests.

There are several types of treated wood that the homeowner is likely to encounter.

**Creosote.** Creosote-treated wood was the first developed and is still used for railroad ties, highway bridges and marine structures like docks and sea walls. Used railroad ties are often sold to homeowners who use them as inexpensive landscape timbers. Creosote-treated wood should be resistant to insect feeding and decay although railroad ties may house carpenter ant colonies because carpenter ants do not feed on the wood, but tunnel into it to build a colony.

**Chromated Copper Arsenate (CCA).** CCA pressure-treated wood has a greenish cast and is highly resistant to termite infestation and decay. Invented in 1933, CCA-treated wood has been widely available since the 1970s; literally millions of decks have been built of CCA-treated wood. The copper acts as the main fungicide and also provides some protection against termites. Arsenic provides protection against termites and copper-tolerant decay fungi. Chromium helps to bond and "fix" the chemical components to the wood. The problem is that arsenic is a known carcinogen.

The Environmental Protection Agency and the leading companies in the wood-preservative industry came to an agreement to remove all residential use and sales of wood products treated with CCA (Chromated Copper Arsenate) ended as of January of 2004. However, CCA-treated wood

products will be still available for use in some industrial, highway, and agricultural applications. These uses will include wood used as poles, piles, guardrail posts, and wood used in saltwater marine exposures.

This decision by manufactures to phase out the use of CCA-treated wood for residential structures has people asking what to do with existing structures made from pressure-treated wood. The EPA does not suggest tearing down structures made of CCA-treated wood. Many feel that applying coatings and sealants to the wood might minimize any chance of exposure to arsenic, although this is a topic of some debate. According to the EPA, people should take common sense precautions, especially when it comes to children. Kids should wash hands after playing on structures and keeping food from direct contact with CCA-treated wood.

**Alkaline Copper Quaternary (ACQ).** This treated wood has been used successfully for more than 10 years. Although it looks like ordinary pressure treated lumber, ACQ does not contain chromium or arsenic which is used in CCA treated lumber as a preservative. Instead, it is a mix of copper and a quaternary ammonium compound, nicknamed quat. The copper-quats work together to protect the lumber from a wide range of rot and decay. Quats are fungicides that attack decay organisms. ACQ treated wood has been tested and found to have performance characteristics similar to wood treated with CCA. Preserve®, Preserve Plus®, and NatureWood® Preserves are brand names for ACQ pressure-treated wood. Preserve Plus® is ACQ pressure-treated wood with a built-in water repellent. More types of wood treated with ACQ is available.

**Copper Boron Azole (CBA).** CBA is a copper-based preservative with an organic fungicide. The treated wood is a dark honey brown color and turns a silver-gray after it weathers. The brown color can be restored by lightly sanding the outer layer. Wood products treated with Copper Azole have been used effectively around the world since 1992. Copper Azole is a fixed preservative approved for full exposure to above ground, ground contact, and freshwater applications. It provides long-term resistance to termites and fungal decay in ground contact and aboveground applications. CBA treated wood can be used for most applications where CCA is used such as decks, walkways, gazebos, picnic tables, play structures, etc. It is not approved for wood foundations. Wolmanized Natural Select™ is a brand name for CBA-treated wood.

**Table 1. Minimum recommended ACQ retentions for various applications.**

Application	Retention (lbs./cu. ft.)	Uses
Above ground decking using <i>Sapwood species</i> (Southern pine, ponderosa pine, red pine, radiata pine, and caribbean pine)	0.15 + water repellent	Decking, hand rails, spindles, trellises, gazebos, fence boards
Above ground decking using <i>Heartwood species</i> (Douglas fir, western hemlock, hem-fir, lodgepole pine, jack pine and redwood)	0.25 + water repellent	
Above ground - general use	0.25	Framing lumber, trim & fascia, flooring, sill plates
Ground contact	0.40	Deck support posts, fence posts, landscaping, piers, docks
Critical structural members	0.60	Permanent wood foundations, timbers, building poles

**Sodium Borates.** Borates are also effective at protecting wood from decay under the right circumstances, however they are very different chemicals. The copper-based preservatives listed above chemically bond to the wood -- in other words, it is “fixed” in the wood and cannot diffuse throughout the piece nor can it wash out. This means copper-based treated wood can be used outdoors or even submerged in water. Borate, on the other hand, is diffusible -- in other words, it doesn’t lock on to the wood like copper-based preservatives. The advantage of diffusion is borate’s ability to keep moving deeper into the wood after pressure treatment. The disadvantage is that borate can leach out of treated wood that is continuously exposed to water. Borates are approved only for above-ground applications that are continuously protected from water, such as sill plates and other enclosed structural framing.

**How long will treated wood last?** It depends on the use and location. For best results, it is important that you use a treatment level (retention) appropriate to the end use. Thus, for an above-ground application (e.g., flooring) 0.25 per cubic foot ACQ is suitable. For ground-contact applications, 0.40 per cubic foot ACQ is appropriate.

## Other Options

Naturally resistant woods include redwood, cypress and cedar. These woods are somewhat resistant to termites, although they are not as resistant as treated lumber. For maximum termite and rot resistance, it is important to use the heartwood where resistant compounds are concentrated. Construction common grade wood contains sapwood and, like any nondurable wood, would only last a few years with ground contact.

**Plastic and Composite Materials.** There are two types of lumber products made from recycled plastic. One is 100% plastic. The other type is a composite material made from recycled plastic and waste wood fiber, like sawdust.

Unlike traditional lumber, plastic and wood composite lumber needs no maintenance or sealing. Plastic lumber does not splinter, rot, chip or warp and is impervious to insects. Like wood products, it can be sanded and fastened using traditional tools and methods. Plastic lumber is commonly available in three grades, hollow, solid, and structural solid. Hollow grade plastic lumber can be used for light-load applications such as low-load deck surfaces, fences, and shutters. Regular solid grade plastic lumber can be used for medium-to-light load applications, such as deck surfaces and planters. Structural grade plastic lumber has a 20% fill of fiberglass to provide superior strength and reduce the expansion and contraction properties.

Composite products have guarantees ranging from 10 to 50 years. Even though plastic wood may cost more initially than traditional wood, there can be long term savings due because of the low maintenance and longevity.

**Termite Shields.** Metal termite shields are widely used in new construction in the southern U.S. where there is a very high likelihood of termite infestation. Termite shields are not used very often in northern climates but could be installed by home builders. These shields will not protect a structure from termites but, when properly installed, force termites to tube around them and make tubing more evident. They would be very expensive to install in existing structures.

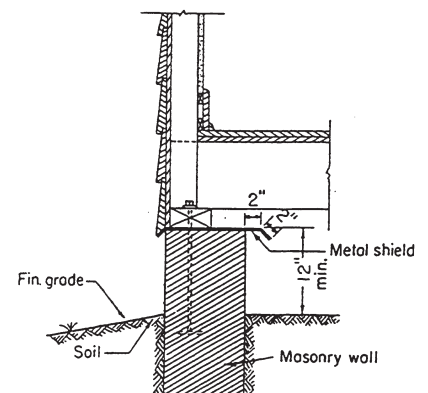

**Figure 4-4.** Termite shield over uncapped masonry wall.

Termite shields are sheets of a noncorroding metal placed between the concrete or solid masonry walls and structural wood. To be properly installed, lengths of metal should be carefully overlapped and soldered or riveted to form a continuous shield around the foundation. It should be emphasized that termite shields will not protect a structure from termites but force termites to tube around them where the tubes will be more visible. To be useful, regular inspections are needed and additional control methods may be needed.

**Sand (or crushed stone) Barriers.** In the late 1950's, two researchers discovered that subterranean termites were unable to tunnel through sand of a specific particle size. This discovery suggested that surrounding a structure with sand could prevent termite entry into a home. Sand or crushed stone barriers can be applied in crawl spaces, under slab foundations, and next to foundation walls.

However, not just any sand or crushed stone will prevent termites. The size of the sand or crushed stone particles is critical to the success of a barrier. Sand/crushed stone size should be no larger or smaller than that able to sift through a 16-mesh screen. Particles smaller than 16-grit can be carried away by termite workers; larger particles can support tube construction. Sand or crushed stone barriers are routinely done on new construction in Australia and Hawaii. In the continental U.S., some companies in California are providing treatments, but this novel treatment has not been used much in the rest of the U.S.

**Stainless Steel Mesh.** Another physical barrier is stainless-steel wire mesh. Research has shown it to be extremely effective, even in very high termite areas. Currently a company in Australia is marketing mesh (0.45 mm x 0.86 mm) that is being sold in 100-ft stainless steel wire rolls and being used during building construction. It can be shaped and fitted around pipes, posts, foundations and trenches. Because of cost, it has limited utility in post construction applications and will probably be used mainly in custom-built homes.

**Steel Studs.** Steel studs used during new construction or remodeling can help reduce the risk of termite infestation. If the walls contain metal instead of wooden studs, the termites can't damage them. However, termites can build mud tubes on the metal studs to gain access to wood in other parts of the house.

**Concrete home.** One of the latest trends in new home construction is the use of concrete. Not only is the concrete used for basement walls and foundations, but it is now being used in whole house wall, ceiling, floor, and roof construction. The poured concrete house comes very close to a "termite proof" home. Keep in mind that if any wood is used in the construction of the house and if termites are in the soil surrounding the house, the termites can potentially find the wood.